

LETOURNEAU

A Keppel Company

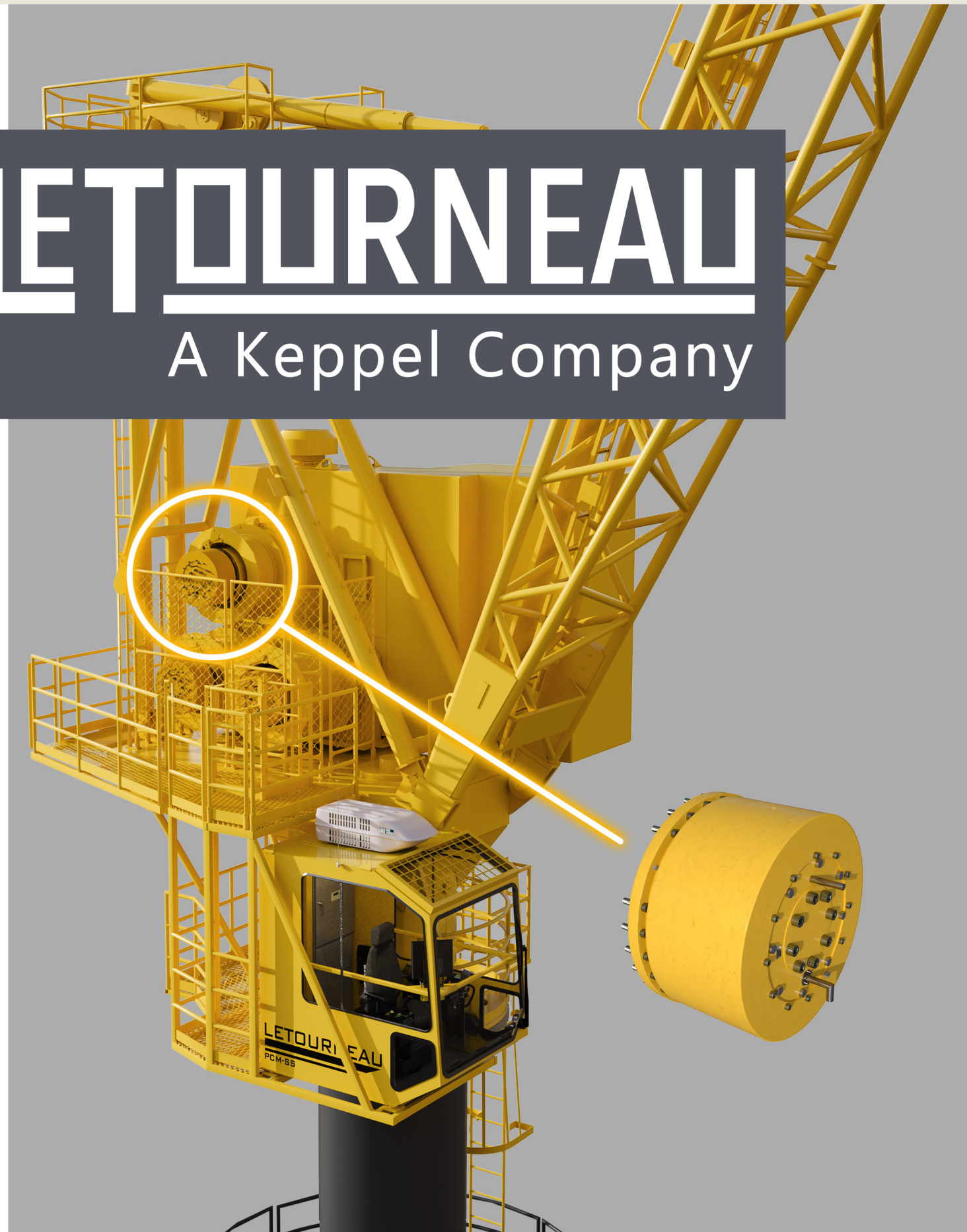

Secondary Brake
Upgrade Package
For LeTourneauTM PCM-SS Cranes

Features

- Provides secondary braking through independent load path at the drum
- Fail-safe design: spring set/hydraulic release
- Modular configuration for installation on boom, auxiliary and/or main hoists
- Proportional braking for power-loss load lowering of any hoist
- Pre-assembled gearbox/brake unit minimizes field installation downtime
- Compatible with existing wire rope drum, motor, and primary brake

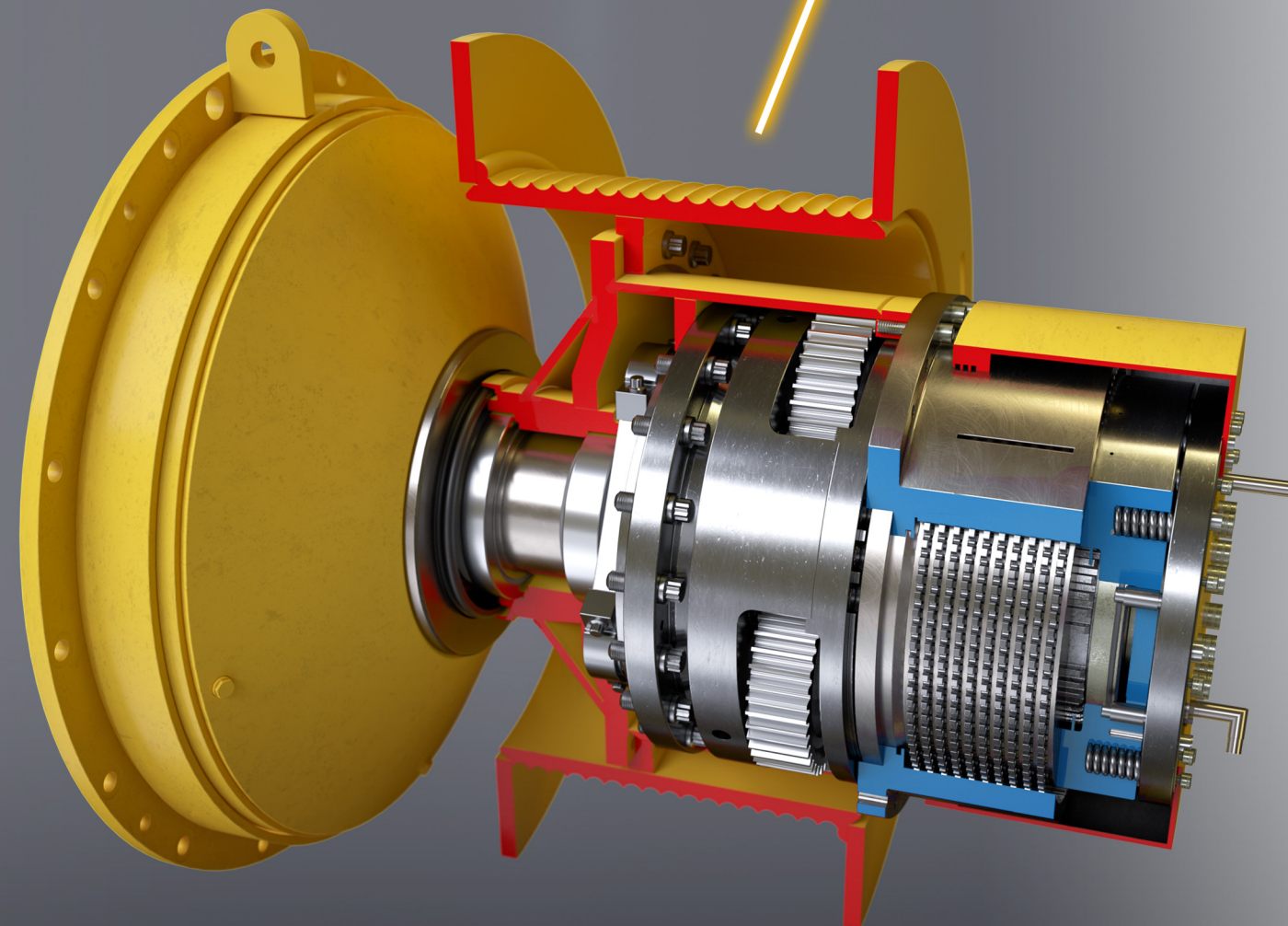
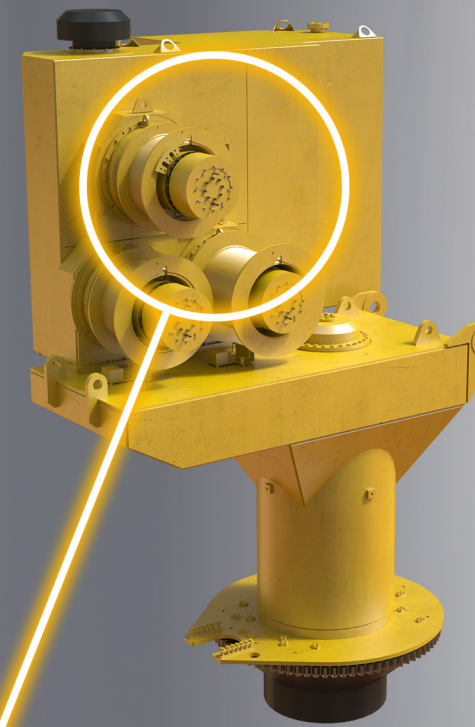

SpareParts.usa@keppelletourneau.com

SpareParts.sg@keppelletourneau.com

SpareParts.uae@keppelletourneau.com

Copyright 2018 Keppel LeTourneau.
All rights reserved.

US and Foreign Patents Pending.

Specifications and data presented in this brochure is for general information only and is subject to change without notice and it is not intended for design purposes. Although every effort has been made to maintain the accuracy and reliability of its contents, Keppel LeTourneau in no way assumes responsibility for liability for any loss, damage or injury resulting from the use of the information and data herein.